

UniversalLine

Intro

Universalline cabinets are suitable for office, equipment rooms, infrastructural cabling of civil engineering, telecommunication and IT networks.



GENERAL CHARACTERISTICS

- Wide range of sizes from 16U to 47U
- 600 and 780 mm width, 600, 800 and 1000 mm depth options
- Load carrying capacity 1000 kg
- Depth adjustable 19" mounting uprights even when the cabinet is fully loaded
- 4 way access; removable, lockable doors and side panels
- Easy disassembling structure with spring hinge system
- 115 degree front/rear door openings
- Baying kit option



HIGH CABLING CAPACITY WITH EXTENSIVE CABLE ENTRIES

Universalline 19' free standing cabinets comply with all international standards in professional networking.

- Main structure has 24 fold frames for increased stability
- Front glass door and metal rear door in standard, perforated and/or solid metal doors are the other options
- Single and double metal rear door construction with brushed cable entry on top and bottom
- Front doors have a framed glass structure which is tempered, anti-static, secure and smoked glass(4 mm thickness)
- Cables protected and fixed by rubber edge sliding cover
- More efficient passive ventilation with Pagoda style top cover
- Plint, floor fixing kit, casters besides standard leveling feet
- EN 61587, IEC 60917, IEC 60297 standards, RoHS compliancy, EAC and TSE certified
- Electrostatic powder coated with RAL 9005 (Black) and RAL (7035) options



UniversalLine

PRODUCT REFERENCE

PRODUCT REFERENCE*	U HEIGHT	WIDTH OVERALL (mm)	DEPTH OVERALL (mm)	DEPTH MAX MOUNTING (mm) PROFILE	HEIGHT VERTICAL MOUNTING PROFILE (mm)	HEIGHT WITHOUT LEVELLING FEET (mm)	HEIGHT WITH LEVELLING FEET (mm)	HEIGHT WITH CASTERS (mm)
UNC16U6060...	16	600	600	390	715	865	880	945
UNC16U6080...	16	600	800	555	715	865	880	945
UNC20U6060...	20	600	600	390	890	1042	1057	1122
UNC20U6080...	20	600	800	555	890	1042	1057	1122
UNC22U6060...	22	600	600	390	980	1131	1146	1211
UNC22U6080...	22	600	800	555	980	1131	1146	1211
UNC22U8080...	22	800	800	555	980	1131	1146	1211
UNC26U6060...	26	600	600	390	1160	1309	1324	1389
UNC26U6080...	26	600	800	555	1160	1309	1324	1389
UNC26U6010...	26	600	1000	740	1160	1309	1324	1389
UNC26U8080...	26	800	800	555	1160	1309	1324	1389
UNC26U8010...	26	800	1000	740	1160	1309	1324	1389
UNC32U6060...	32	600	600	390	1422	1576	1591	1656
UNC32U6080...	32	600	800	555	1422	1576	1591	1656
UNC32U6010...	32	600	1000	740	1422	1576	1591	1656
UNC32U8080	32	800	800	555	1422	1576	1591	1656
UNC32U8010	32	800	1000	740	1422	1576	1591	1656
UNC36U6060...	36	600	600	390	1603	1754	1769	1834
UNC36U6080...	36	600	800	555	1603	1754	1769	1834
UNC36U6010...	36	600	1000	740	1603	1754	1769	1834
UNC36U8080...	36	800	800	555	1603	1754	1769	1834
UNC36U8010...	36	800	1000	740	1603	1754	1769	1834
UNC39U6060...	39	600	600	390	1735	1887	1902	1967
UNC39U6080...	39	600	800	555	1735	1887	1902	1967
UNC39U6010...	39	600	1000	740	1735	1887	1902	1967
UNC39U8080...	39	800	800	555	1735	1887	1902	1967
UNC39U8010...	39	800	1000	740	1735	1887	1902	1967
UNC42U6060...	42	600	600	390	1889	2021	2036	2101
UNC42U6080...	42	600	800	555	1889	2021	2036	2101
UNC42U6010...	42	600	1000	740	1889	2021	2036	2101
UNC42U8060...	42	800	600	390	1889	2021	2036	2101
UNC42U8080...	42	800	800	555	1889	2021	2036	2101
UNC42U8010...	42	800	1000	740	1889	2021	2036	2101
UNC45U6060...	45	600	600	390	2020	2153	2168	2233
UNC45U6080...	45	600	800	555	2020	2153	2168	2233
UNC45U6010...	45	600	1000	740	2020	2153	2168	2233
UNC45U8080...	45	800	800	555	2020	2153	2168	2233
UNC45U8010...	45	800	100	740	2020	2153	2168	2233
UNC47U6060...	47	600	600	390	2110	2244	2259	2324
UNC47U6080...	47	600	800	555	2110	2244	2259	2324
UNC47U6010...	47	600	1000	740	2110	2244	2259	2324
UNC47U8080...	47	800	800	555	2110	2244	2259	2324
UNC47U8010...	47	800	1000	740	2110	2244	2259	2324

* Pls complete the reference code referring the "Reference Code Creation" on next page.

DOOR SELECTION TABLE AND REFERENCE CODE CREATION

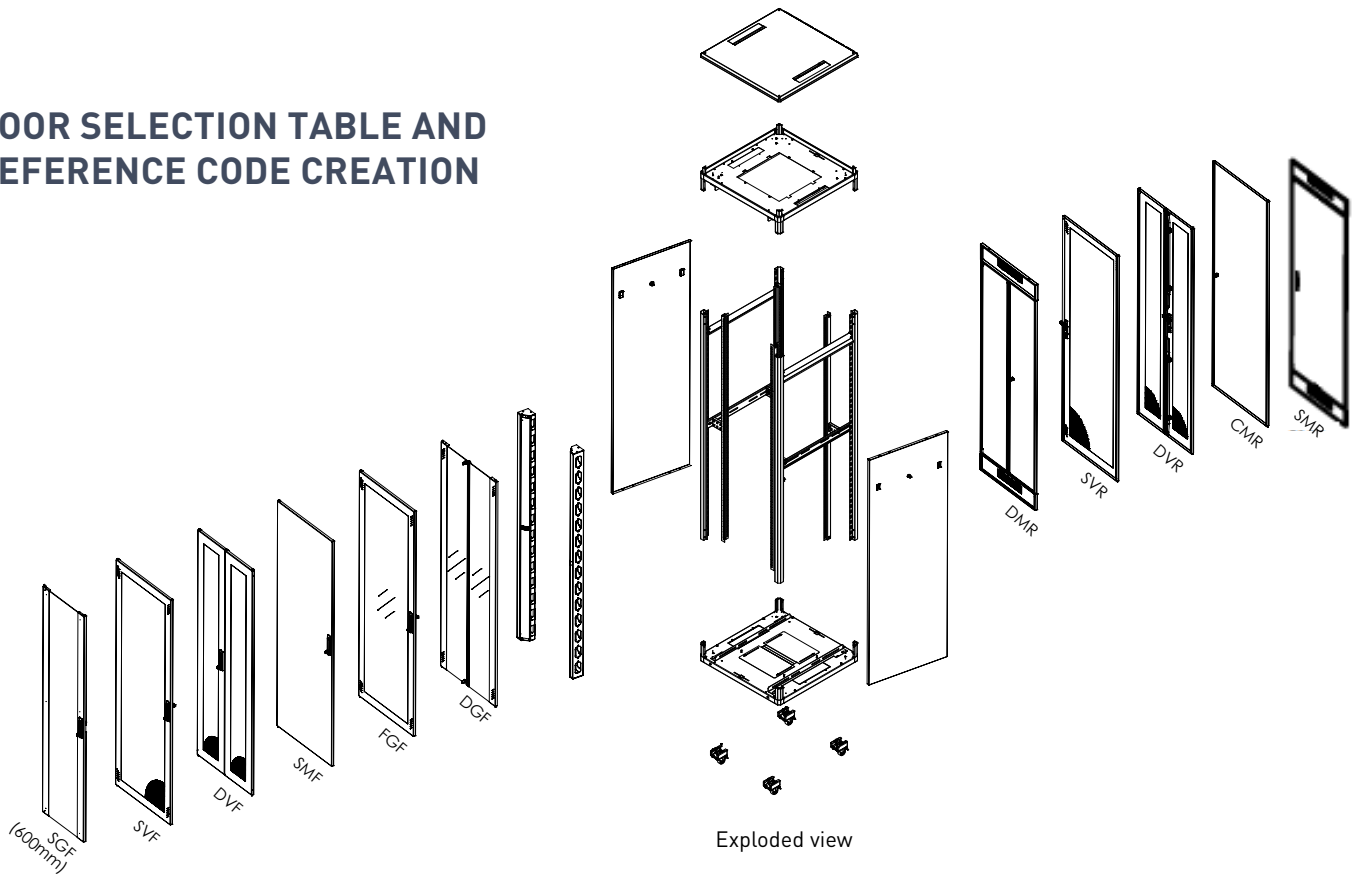

DOOR CODE	DESCRIPTION	UNC W= 600 MM	UNC W= 800 MM
FRONT			
SGF	Single Glass Front Door, single point locking	Standard	
DGF	Double Glass Front Door, two point barrel locking		Standard
FGF	Single, Full Frame Glass Front Door, single point locking	Optional	Optional
SVF	Single Vented Front Door, 63% perforated, single point locking	Optional	Optional
DVF	Double Vented Front Door, 63% perforated, three point locking		Optional
SMF	Solid Metal Front Door	Optional	Optional
REAR			
CMR	Single Solid Metal Rear Door	Optional	Optional
DMR	Double Solid Metal Rear Door with cable entries on top and bottom	Optional	Standard
SVR	Single Vented Rear Door, 63% perforated, single point locking	Optional	Optional
DVR	Double Vented Rear Door, 63% perforated, three point locking	Optional	Optional
SMR	Solid Metal Rear Door(s) with cable entries on top & bottom	Standard	Optional

Marked are also Default Config.

REFERENCE CODE CREATION

Example: UNC47U8080_M2_L_DVFSVR

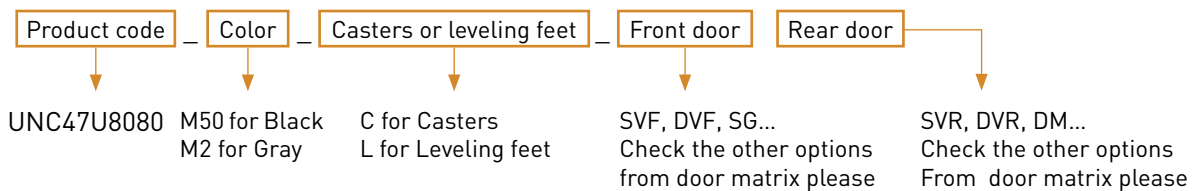

TECHNICAL DRAWINGS
W=600 mm CABINETS

BOTTOM VIEW

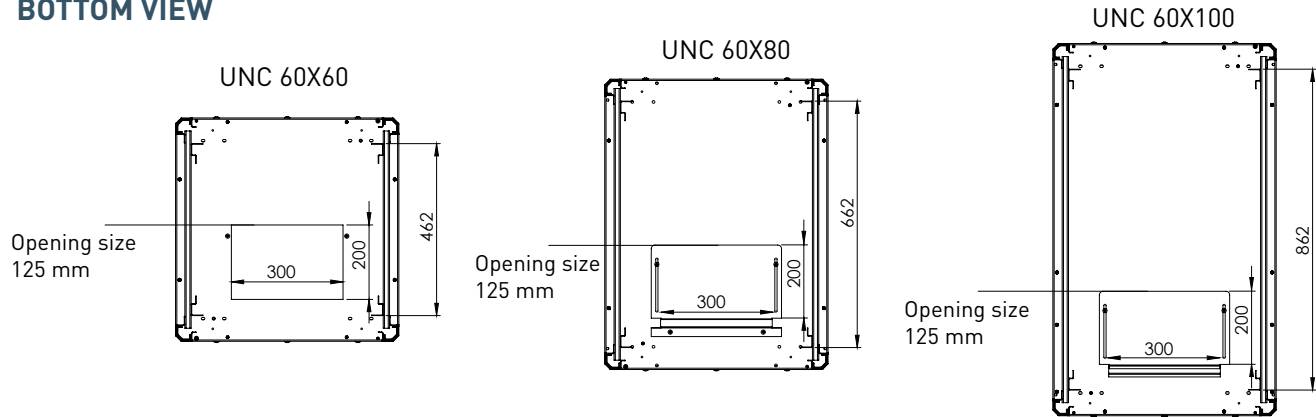

TOP VIEW

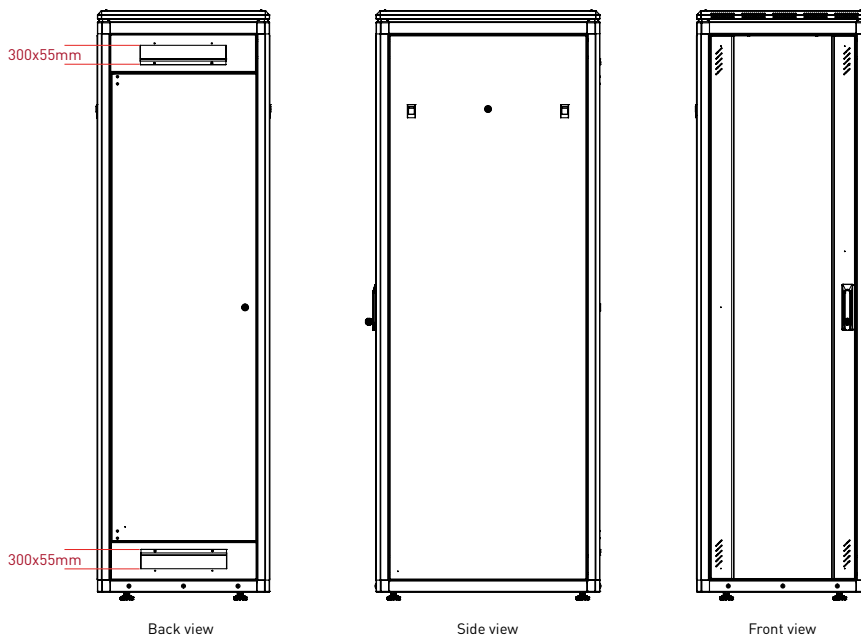
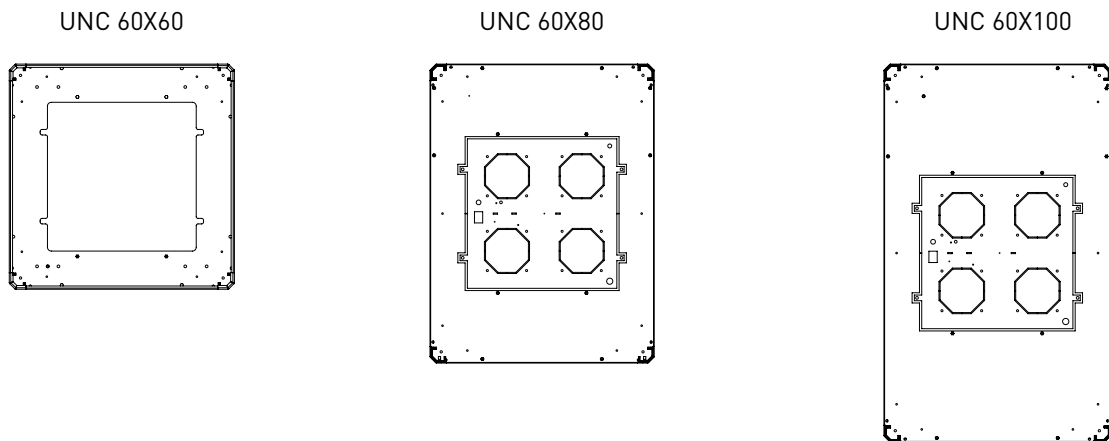

H= Enclosure height

TECHNICAL DRAWINGS

W=780 mm CABINETS

BOTTOM VIEW

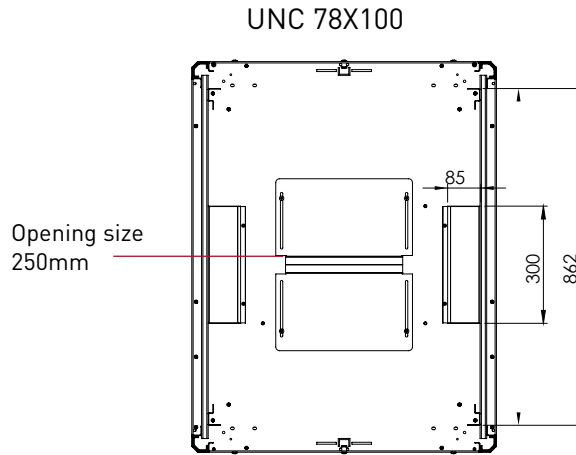
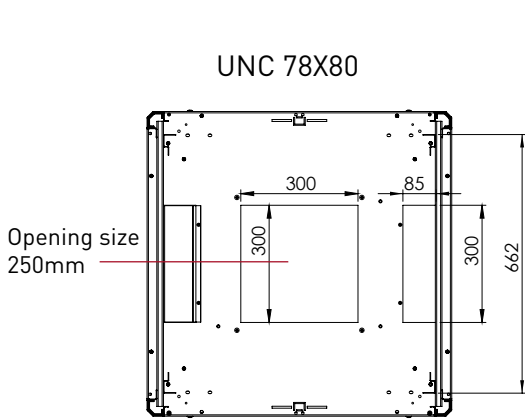

TOP VIEW

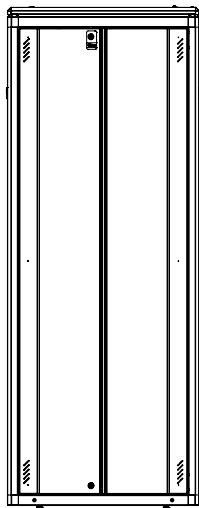
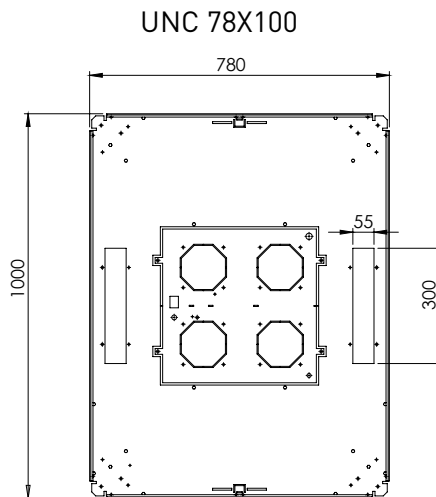
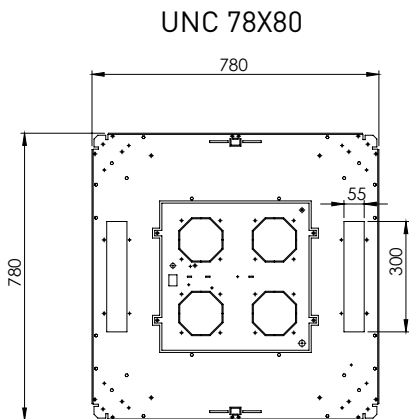

Front view

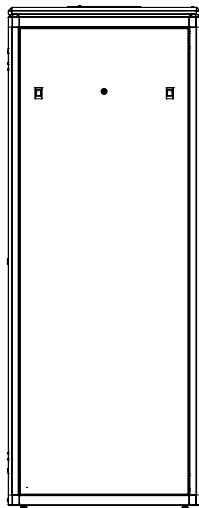

Side view

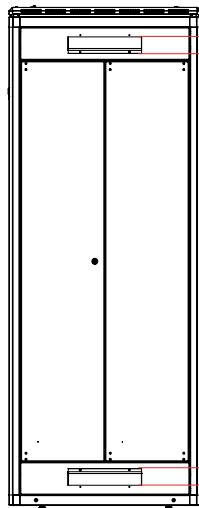

Back view

Optional ETSI

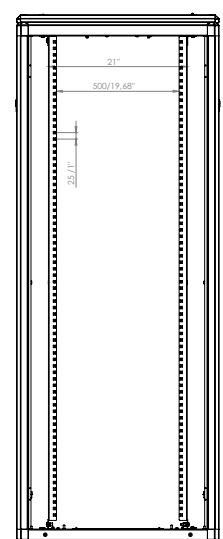
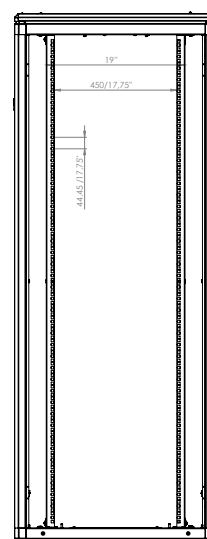

H= Enclosure height

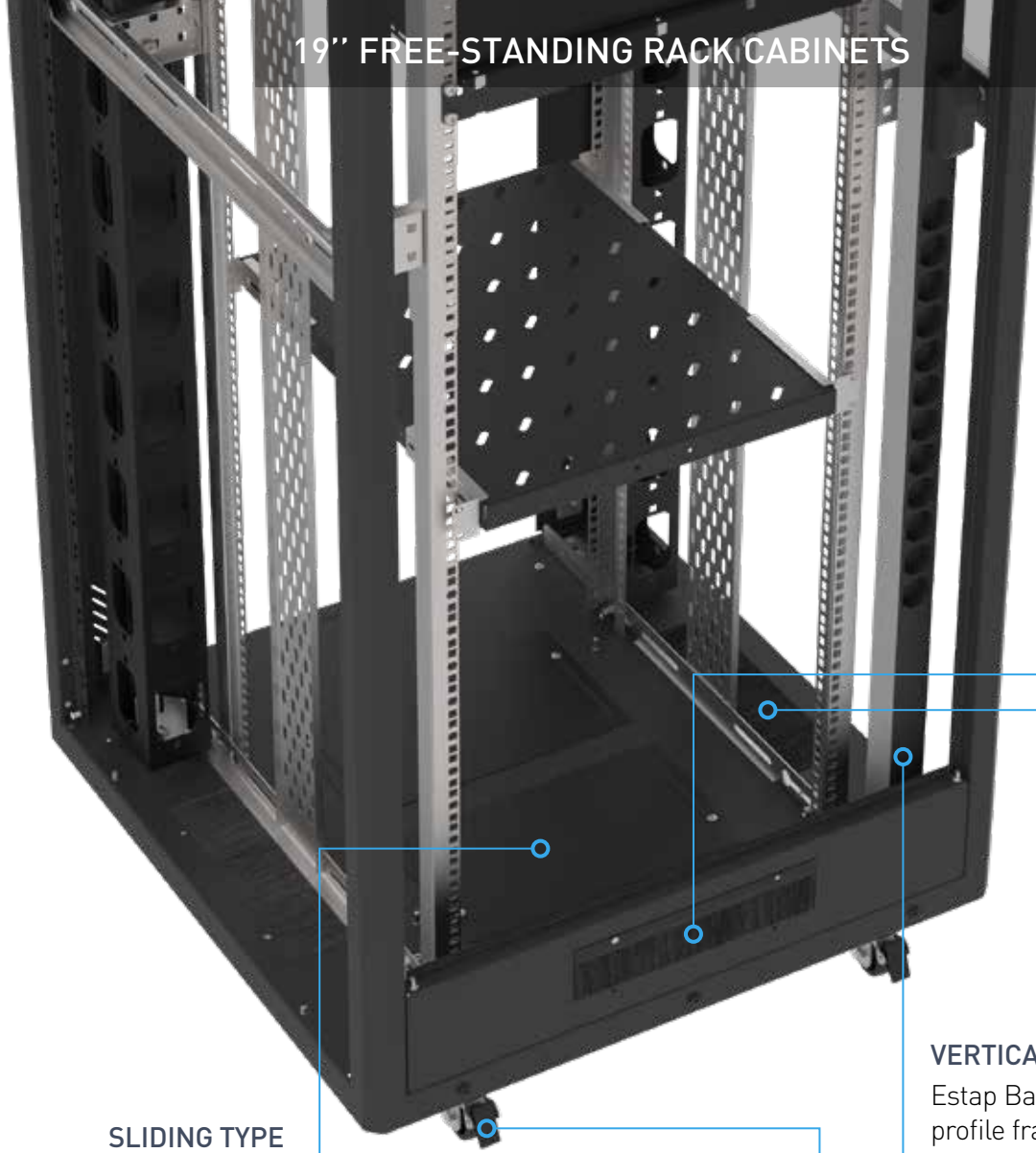

SLIDING TYPE CABLE ENTRY

Bottom panel have two cable entries which are sliding type with rubber edges.

CASTER AND LEVELLING FEET

Rotational type casters, 2 pieces front have lockable function
Levelling feet: Height adjustment from the floor 250 kg. load carrying capacity of each wheel and each levelling feet.

VERTICAL BASIC PDU

Estap Basic pdu has aluminium profile frame, on/off switch and circuit breaker options. Schuko, C13-C19 and UK socket types are available.

FLOOR FIXING KIT

Fixing the cabinet to floor for better stability. 4-point fixing. Galvanized sheet metal.

LED LIGHT

Effective and powerful lighting. Different dimensions 19", 1U, with ON/OFF switch, automatic door with ON/OFF switch or LED with sensor.



FAN MODULE

2 or 4 pcs. of fan on a module, with ON/OFF, analog or digital thermostat functions. Complete inner wiring. 1U

GROUNDING CONTINUITY

Grounding cables for all metal components. Cable connections with bolts and nuts for all doors.

UniversalLine Accessories

FIXED AND SLIDING SHELF

Fixing points at the sides of rear and front 19" uprights.

Vented for air circulation, adjustable depth, sheet steel material. Available for all kind of cabinet depths like 600mm, 800mm and 1000mm.

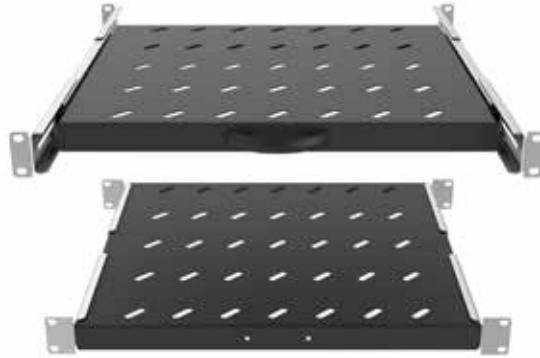

BRUSHED CABLE ENTRY

There are two brushed cable entries on the bottom and top panels.

CABLE TRAY

Options from 16U to 47U.
The galvanized coating must be perforated to provide length and cable installation along the height of the cabinet.
Unified cable tray for every cabinet range.

DOOR CABLE ENTRY

Optional brushed top and bottom door cable entries.

VERTICAL CABLE ORGANIZER

Options from 16U to 47U.
Large internal volume that protects all kind of electric and data cables and patch cords.
It attaches to the sides along 19" uprights and have cable entry holes.

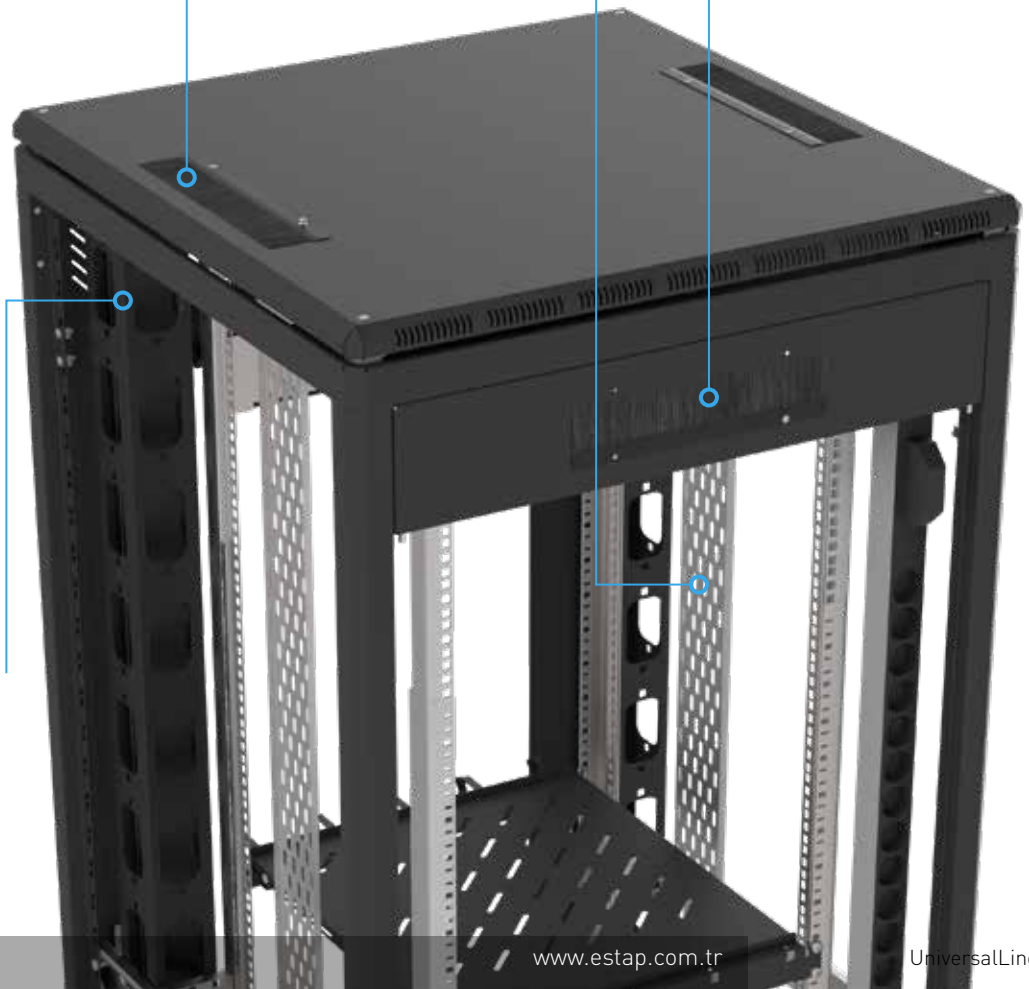

The image is for the width of 800 mm cabinet

UniversalLine Accessories

CASTER AND LEVELLING FEET

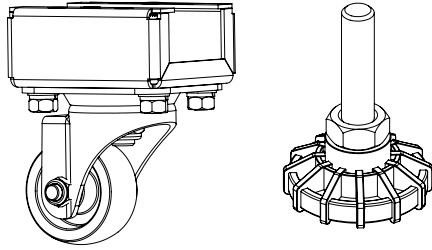

PRODUCT REFERENCE	DESCRIPTION
M44STB01_01TKR_CKR	Casters, 2 pcs. front are lockable
MG44STB01_01PNY_CKR	Levelling feet (1 set = 4 pcs.)

PLINTH

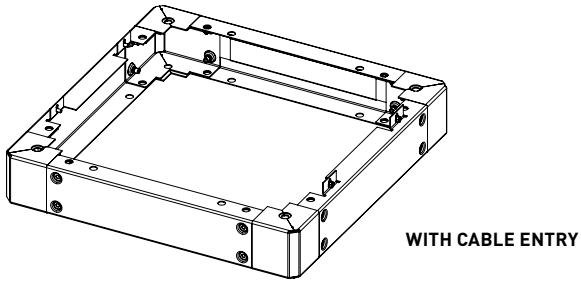

PRODUCT REFERENCE	DESCRIPTION
M11PNT66_01M50	Plinth with cable entry for Universalline, Width=600 mm / depth=600 mm
M11PNT68_01M50	Plinth with cable entry for Universalline, Width=600 mm / depth=800 mm
M11PNT610_01M50	Plinth with cable entry for Universalline, Width=600 mm / depth=1000 mm
M11PNT88_01M50	Plinth with cable entry for Universalline, Width=800 mm / depth=800 mm
M11PNT810_01M50	Plinth with cable entry for Universalline, Width=800 mm / depth=1000 mm

HEAVY DUTY TYPE SHELF

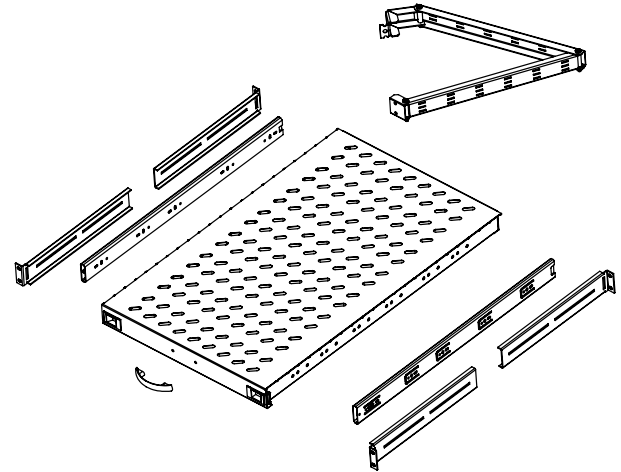
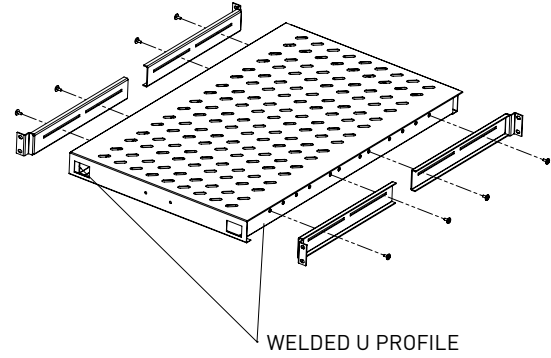

PRODUCT REFERENCE	DESCRIPTION	HxWxD (mm)
M55SR720_01M50	19", heavy duty fixed shelf, adjustable in depth	50x483x720
M55HR720_01M50	19", heavy duty sliding shelf, adjustable in depth, vented, complete with rear cable management system	50x483x720

Note: Color code "M50" is RAL 9005 black, "M2" RAL 7035 light grey option is available

19" KEYBOARD DRAWER

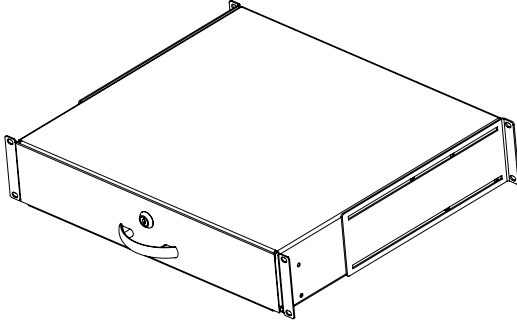

PRODUCT REFERENCE	DESCRIPTION	DIMENSIONS WxHxD (mm)
M44CEK2U_01M50	2U 19" drawer, lockable suitable up to depth=800mm. Cabinets, for D=1000 mm cabinet usage extra brackets available in package, sheet steel material and load carrying capacity is 25 kg.	483x88x400
M44CEK3U_01M50	3U 19" drawer, lockable suitable up to depth=800mm. Cabinets, for D=1000 mm cabinet usage extra brackets available in package, sheet steel material and load carrying capacity is 25 kg.	483x133x400

FIXED AND SLIDING SHELVES

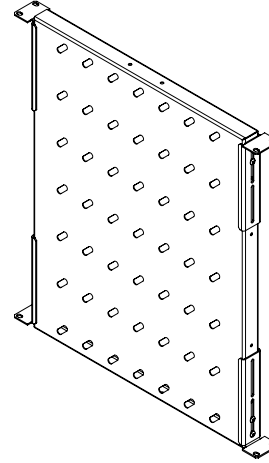
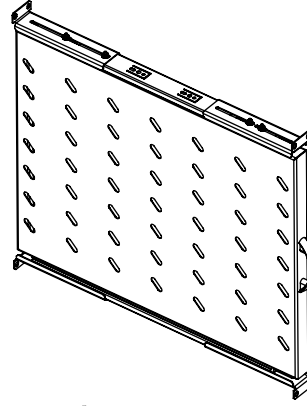

PRODUCT REFERENCE	DESCRIPTION
SHLFIX60M50	D= 600 mm fixed shelf module with slots, load capacity 50 kg., Ral9005, depth of the shelf D= 372 mm, 4-points fixed. Only suitable for 600 mm depth cabinets.
SHLFIX80M50	D= 800 mm fixed shelf module with slots, load capacity 50 kg., Ral9005, depth of the shelf D= 530 mm, 4-points fixed. Only suitable for 800 mm depth cabinets.
SHLFIX100M50	D= 1000 mm fixed shelf module with slots, load capacity 50 kg., Ral9005, depth of the shelf D= 696 mm, 4-points fixed. Only suitable for 1000 mm depth cabinets.
SHLSLD60M50	D= 600 mm sliding shelf module with slots, load capacity 30 kg., Ral9005, depth of the shelf D= 372 mm, 4-points fixed. Only suitable for 600 mm depth cabinets.
SHLSLD80M50	D= 800 mm sliding shelf module with slots, load capacity 30 kg., Ral9005, depth of the shelf D= 530 mm, 4-points fixed. Only suitable for 800 mm depth cabinets.
SHLSLD100M50	D= 1000 mm sliding shelf module with slots, load capacity 30 kg., Ral9005, depth of the shelf D= 696 mm, 4-points fixed. Only suitable for 1000 mm depth cabinets.

Note: Color code "M50" is RAL 9005 black, "M2" RAL 7035 light grey option is available

UniversalLine Accessories

FAN MODULE

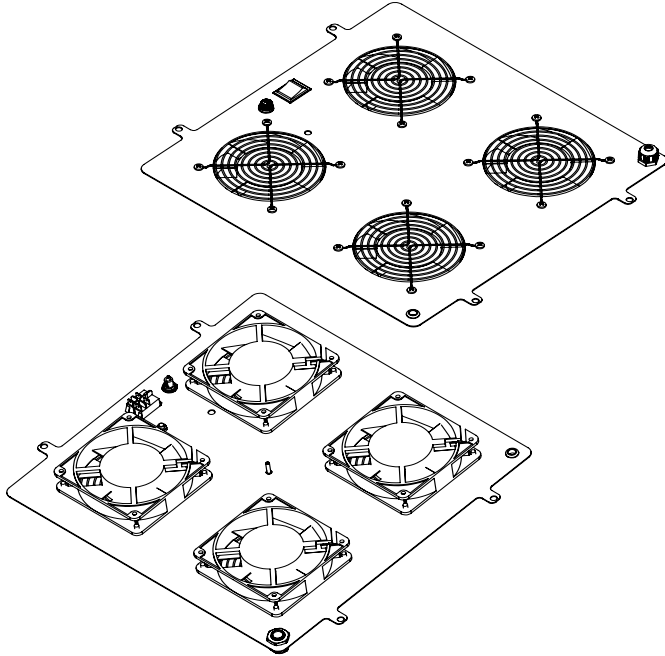

PRODUCT REFERENCE	DESCRIPTION
M44HV2FDT_01M50	Fan module, 2 fan + digital thermostat, 2P+E plug, schuko std., 2 pre-cut hole
M44HV2FDT_01M50_UK	Fan module, 2 fan + digital thermostat, 2P+E plug, UK std., 2 pre-cut hole
M44HV2FT_01M50	Fan module, 2 fan + analog thermostat, 2P+E plug, schuko std., 2 pre-cut hole
M44HV2FT_01M50_UK	Fan module, 2 fan + analog thermostat, 2P+E plug, UK std., 2 pre-cut hole
M44HV2F_01M50	Fan module, 2 fan + On/Off, 2P+E plug, schuko std., 2 pre-cut hole
M44HV2F_01M50_UK	Fan module, 2 fan + On/Off, 2P+E plug, UK std., 2 pre-cut hole
M44HV4FDT_01M50	Fan module, 4 fan + digital thermostat, 2P+E plug, schuko std., 4 pre-cut hole
M44HV4FDT_01M50_UK	Fan module, 4 fan + digital thermostat, 2P+E plug, UK std., 4 pre-cut hole
M44HV4FT_01M50	Fan module, 4 fan + analog thermostat, 2P+E plug, schuko std., 4 pre-cut hole
M44HV4FT_01M50_UK	Fan module, 4 fan + analog thermostat, 2P+E plug, UK std., 4 pre-cut hole
M44HV4F_01M50	Fan module, 4 fan + On/Off, 2P+E plug, schuko std., 4 pre-cut hole
M44HV4F_01M50_UK	Fan module, 4 fan + On/Off, 2P+E plug, UK std., 4 pre-cut hole

HORIZONTAL CABLE MANAGER

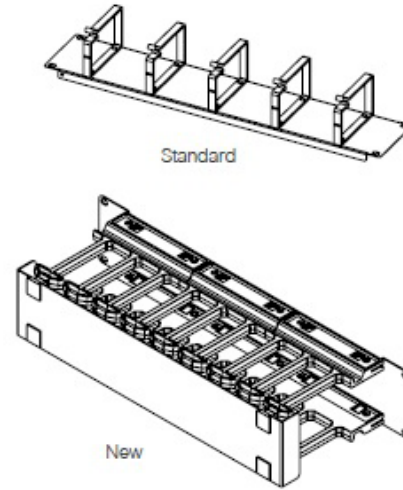

PRODUCT REFERENCE	DESCRIPTION	DIMENSIONS WxHxD (mm)
E44ORG1U_01M50	1U 19" cable management panels with 5 metal rings	483x44x80
E44ORG1UPLST_01M50	1U 19" cable management panels with 4 plastic rings	483x44x80
E44ORG1UN_01M50	1U 19" cable management panel, channel type and with removable cover	483x44x71
E44ORG2F_01M50	1U 19" cable management panels with front patch cord access holes, L shaped, rear tray for cable support	483x44x124
E44ORG2F_01M50BN	1U 19" cable management panels with front patch cord access holes, basic blank panel shaped	483x44x10
E44ORG2U_01M50	2U 19" cable management panels with 5 rings	483x88x76
E44ORG1F_01M50	1/2U 19" cable management panels with front patch cord access holes	483x22x100
E44ORG2UFT_01M50	2U 19", Cable Management Panels with 5 Metal Rings - Finger Type	483x88x166

VERTICAL CABLE MANAGER



PRODUCT REFERENCE	DESCRIPTION
M44ORG16_03M50	16U Vertical Cable Organizer
M44ORG20_03M50	20U Vertical Cable Organizer
M44ORG22_03M50	22U Vertical Cable Organizer
M44ORG26_03M50	26U Vertical Cable Organizer
M44ORG32_03M50	32U Vertical Cable Organizer
M44ORG36_03M50	36U Vertical Cable Organizer
M44ORG42_03M50	42U Vertical Cable Organizer
M44ORG45_03M50	45U Vertical Cable Organizer
M44ORG47_03M50	47U Vertical Cable Organizer

CABLE TRAY

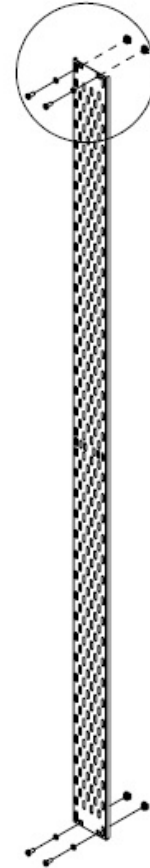

PRODUCT REFERENCE	DESCRIPTION
CT1610	Cable Tray, 16U, w= 100 mm
CT2010	Cable Tray, 20U, w= 100 mm
CT2210	Cable Tray, 22U, w= 100 mm
CT2610	Cable Tray, 26U, w= 100 mm
CT3210	Cable Tray, 32U, w= 100 mm
CT3610	Cable Tray, 36U, w= 100 mm
CT3910	Cable Tray, 39U, w= 100 mm
CT4210	Cable Tray, 42U, w= 100 mm
CT4510	Cable Tray, 45U, w= 100 mm
CT4710	Cable Tray, 47U, w= 100 mm

UniversalLine Accessories

BLANK PANELS

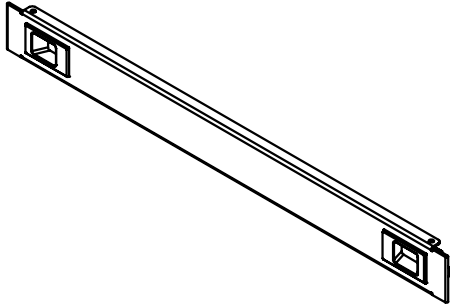

PRODUCT REFERENCE	DESCRIPTION	DIMENSIONS WxHxD (mm)
E44BPN01_0150M	1U 19" Blank panel	483x44x12
E44BPN02_0150M	2U 19" Blank panel	483x88x12
E44BPN03_0150M	3U 19" Blank panel	483x133x12
E44BPN04_0150M	4U 19" Blank panel	483x177x12
E44BPN05_0150M	5U 19" Blank panel	483x222x12
E44BPN06_0150M	6U 19" Blank panel	483x266x12
P44BPN06_01M50	6U 19" Modular plastic blank panel (ABS)	483x266x12

GROUNDING KIT

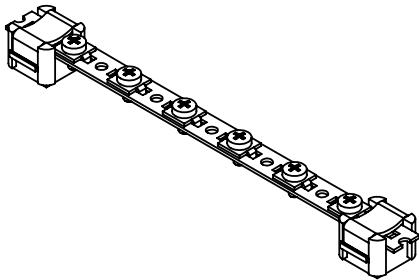

PRODUCT REFERENCE	DESCRIPTION
M44PEB01	Grounding kit, 6 each earthing leads + copper busbar
M44PEB19_01	Grounding kit, 13 each earthing leads + copper busbar

LED LIGHT

PRODUCT REFERENCE	DESCRIPTION	HxWxD (mm)
MAYDNLED-IRM	LED LIGHT	10X300X30

FLOOR FIXING KIT

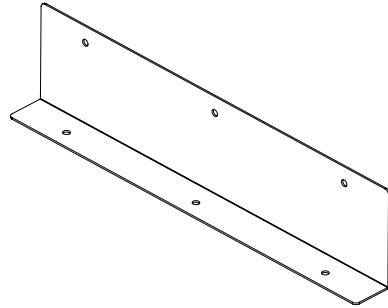

PRODUCT REFERENCE	DESCRIPTION
M44DPR01_01M50C	Floor fixing kit using cabinet with leveling feet
M44DPR01_01M50B	Floor fixing kit using cabinet with caster

BAYING KIT

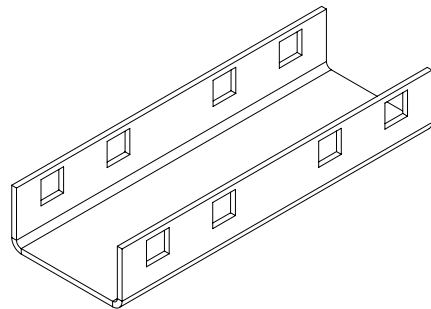

PRODUCT REFERENCE	DESCRIPTION
M44BLG01_01M50	Baying kit

FIXINGS

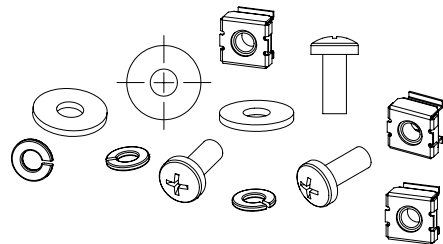

PRODUCT REFERENCE	DESCRIPTION
KFS6X15_20	M6 caged nut, screw, washer (1set=20ea)
KFS6X15_50	M6 caged nut, screw, washer (1set=50ea)

TECHNICAL CHARACTERISTICS

Shatterproof glass with left and right metal frame

GLASS

4 mm thickness full-length smoked, shatterproof, tempered, secure

FRONT DOOR CONSTRUCTION

Single door opening

Front door lock

HANDLE TYPE, SINGLE POINT LOCKING

Adhesive material

High density polyurethane DIN 53479, DIN 53505

HINGE SYSTEM

Spring loaded

DOOR OPENING ANGLE AND SWAPPING

125 degree, possible to swap one side to the other

SIDE PANEL

Solid metal, 1 mm left and right (2ea.)

SIDE PANEL CONSTRUCTION

Lockable, removable c/with slam latches and lock

SIDE PANEL LOCK

Barrel type lock unit, single point + Slam latch (2ea)

REAR DOOR

Solid metal, 1 mm

REAR DOOR CONSTRUCTION

Single opening, solid metal with brushed cable entry on top and bottom.

REAR DOOR LOCK

Barrel type lock unit, single point

HINGE SYSTEM

Spring loaded

DOOR OPENING ANGLE AND SWAPPING

125 degree, possible to swap one side to the other

TOP COVER

Solid metal 1 mm

TOP COVER CONSTRUCTION

Pagoda type structure provides efficient air removal

FRAMEWORK

TOP AND BOTTOM BASE UNITS

Solid metal 1,5 mm

TOP AND BOTTOM BASE UNITS CONSTRUCTION

Completely welded corner socket system

UPRIGHTS

Solid metal, 1,5 mm

UPRIGHTS CONSTRUCTION

Tightly fixed into top and bottom base units 6 times folded

INTERIOR PARTS

19" mounting angles

Solid metal, 1,5 mm

3 times folded 600x600, 600x780 / 1 time folded for 600x1000

"U" marking available 2 ea. at rear, 2 ea. at front

Pre-configured as 19"

Zinc plated, passivated, 8-12 micron.

Adjustable in depth

C TYPE SUPPORT RAILS IN DEPTH

Solid metal, 1,5 mm

3 times folded, 2 ea. at left , 2 ea. at right up

TESTS AND COMPLIED STANDARDS

TESTS AND COMPLIED STANDARDS

- 1) ISO 9001:2015 Quality Management System
- 2) ISO 14001:2015 Environmental Management System
- 3) ISO 27001:2013 Information Security Management System
- 4) ISO 45001:2018 Occupational Health and Safety Management System
- 5) 19" device mounting uprights IEC 297-1
- 6) EN 61587-1 Mechanical structures for electronic equipment.
- 7) All cabinet sizes complies with IEC 297-2.

RESISTANCE TO ENVIRONMENTAL CONDITIONS AND CORROSION;

STABILITY, MECHANICAL SAFETY, RESISTANCE TO STATIC, DYNAMIC AND MECHANICAL LOADS;

RESISTANCE TO VIBRATION, MECHANICAL SHOCK AND IMPACT;

DEGREES OF MECHANICAL PROTECTION PROVIDED BY THE ENCLOSURE (IP20);

ELECTRICAL GROUNDING CONTINUITY;

FIRE AND FLAME RESISTANCE;

Have been tested according to the standard " EN 61587-1" with the normative standards: IEC 60917, IEC 60297, IEC 60068-1, IEC 60068-2, IEC 60695-11-10, IEC 60950-1, contained and certified by the notified organizations::

TSE CERTIFICATE NO

003788-TSE-08/02

EAC CERTIFICATE NO

0443637, 0776963, 0345864, 0401678, 0776653

CORROSION

ISO 9227 Standard complied by the test report METALTEK AB-0547-T / 0157-1

TRANSPORT

ETS 300 019-1-2 Class 2.3 Comply with internal testing

STORAGE

ETS 300 019-1-1 Class 1.2 Comply with internal testing

SURFACE FINISH

Electrostatic powder coated c/with surface treatment , 80 +/- 5 micron paint thickness

PURCHASED PRODUCT CERTIFICATION

SHEET STEEL

EN 10346: 20015 DX51D+Z, EN 10130: 2006 DC01

ELECTROSTATIC POWDER COATING

ISO6860, ISO2409, ISO1520, ISO2815, ISO6272, ISO7253, ISO6270-1, ISO2812
ISO 9001, RoHS

GLASS

TS EN 12150-1, TS EN 1863-1

LOCK

IEC 62474, REACH, RoHS

CASTORS

ISO 9001, TS EN 12532, RoHS

FAN

IEC 60335-2-80:2002, IEC 60335-1:2010